

THE MODERN POWER OP AMP

Power op amps are attractive because they reduce circuit design time enormously. Assembly costs of the power op amp design amount to a fraction of the discrete counterpart due to vastly reduced parts count. Careful attention to the power aspects of a circuit is required, as the well known op amp design rules based on low power devices. The objectives are to maximize reliability plus optimize output power and system efficiency. This application note points out some optimizing techniques and some areas to be especially watchful.

INTERPRETING SPECIFICATIONS

The first step in achieving high power levels is to operate within specifications. This means check the data sheet first. Apex data sheets are divided into product description, absolute maximum ratings, specification table, typical performance graphs, and application hints. Each section should be checked for relevant information.

Absolute maximum ratings are stress levels which, when applied to the amplifier one at a time, will not cause permanent damage. However, proper operation is only guaranteed over the ranges listed in the specifications table. For example, most amplifiers have an absolute maximum case temperature range of -55°C to 125°C . If the specified operating temperature range is less, i.e. -25°C to 85°C , an amplifier may latch to one of its supply rails when operating above that temperature ($+85^{\circ}\text{C}$). However, the device will not sustain permanent damage unless the latched condition also violates the safe operating area. Simultaneous application of two or more of these maximum stress levels, such as maximum power and temperature, may induce permanent damage to the amplifier.

The generally accepted industry method of specifying absolute maximum power dissipation assumes the case temperature is held at 25°C and the junctions are operating at the absolute maximum rating. This standardization provides a yardstick to compare ratings of various manufacturers. However, it is not a reliable operating point. An ideal heatsink is required, and even with the best heatsink, it would still result in reduced product life due to operation at extreme temperatures. APEX recommends maximum junction temperature of 150° or less.

The specifications table should be the prime working document while designing the application. In addition to the minimum/maximum parameters (voltage offset, output capability, etc.), this table contains the guaranteed linear operating ranges: common mode voltage, temperature ranges, power supplies, etc.

Typical performance graphs are most useful in determining performance variation as operating conditions change. For example, all amplifiers are specified for a minimum voltage output at maximum current rating. If your application needs only 75% of this current, you might determine from the typical graph you will gain 0.5V at this level. A safe design will assume output capability of 0.5V better than the specification table, not the actual number on the typical graph. Bear in mind, if your design is based on the typical performance graphs, it will statistically work 50% of the time.

OPTIMIZING THE POWER SUPPLY

To deliver the most output power and achieve maximum efficiency, internal power dissipation must be minimized. This condition is met if the power supply voltage is selected for the minimum voltage necessary to produce the required output. Internal power dissipation is the sum of quiescent power *plus* the product of output current and the supply to output differential. Supply voltage is the only variable for the designer to optimize. Refer to the product data sheet's specified minimum supply to output differential voltage. Each extra volt here dissipates one more watt for every ampere of output current. Trade-offs in this area are not recommended. Deriving required outputs from existing system supplies reduces efficiency if the difference between supply and required output exceeds the supply to output differential of the op amp. Also, this supply vs. efficiency trade-off must be considered when contemplating the use of unregulated supplies. When using unregulated supplies, line and load variations must be taken into consideration along with the ripple content of the supply. The result is a voltage band above the minimum operating voltage required by the power op amp to produce the required output. Power in this band must be dissipated. Voltage above the minimum operating voltage decreases the power handling capability of the power op amp.

The choice is whether to dissipate the power in the power op amp or in a separate regulator. As current levels increase, the dollar per watt cost generally rises faster for the power op amp than it does for a DC regulator.

Usually, unregulated supplies are not economical because they lack transient protection. Power lines are notorious for being extremely noisy. They have high voltage, high speed spikes riding on the sine wave which pass right through the power transformer. Furthermore, the large electrolytic capacitors used for filtering often do not have low equivalent series resistances at those high frequencies. A 1K volt spike on the incoming line can result in an excessive voltage spike at the amplifier supply pin. Destruction of the op amp may be the result. Therefore, line filters and zener clamps are required to eliminate the voltage spikes; thus, the economy of unregulated supplies is reduced.

Once the minimum supply voltages above have been selected, steps need to be taken to minimize IR losses. Some of today's modern hybrid power op amps handle currents higher than most branch circuits in residential wiring. Losses can be kept to a minimum, especially as frequencies increase, if leads are as short as possible between supply and amplifier, as well as between the amplifier and the load. In the video frequency range, where even a few inches of wire have significant inductance, and the skin effect increases the resistance of heavy wires at high frequency, multi-strand litz wire is recommended.

SINGLE OR ASYMMETRIC SUPPLY OPERATION

Asymmetric output swings present another opportunity to optimize power supplies. Consider the circuit of Figure 1. If the symmetric power supplies were used, power dissipation

would be substantially increased, a power op amp with a higher voltage rating would be necessary and output power would be reduced.

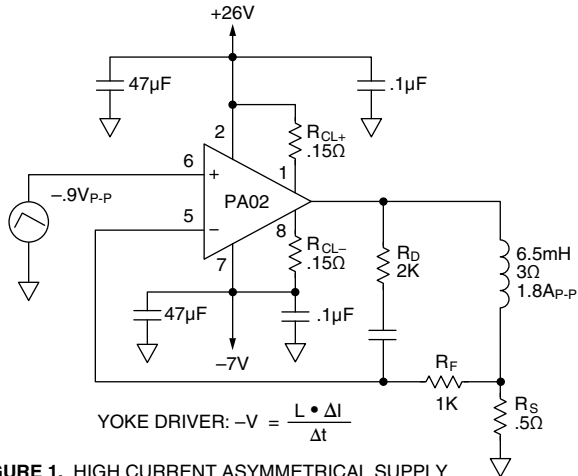

FIGURE 1. HIGH CURRENT ASYMMETRICAL SUPPLY

Fortunately, most power op amps are suitable for operation from a single supply voltage. The common mode operating requirements do, however, impose the limitation that the input voltages not approach closer than 5 to 10 volts to either supply rail (determined by the common mode voltage specification). Thus, single supply operation requires the input signals to be biased 5 to 10V from either supply rail. Figure 2A illustrates one bias technique to achieve this.

Figure 2A illustrates a very practical alternative to single supply operation, a second low voltage supply. This allows ground referenced input signals, but also maximizes the voltage swing of the unipolar output. The 12 volt supply in Figure 2B must usually supply only the quiescent current of the power op amp unless the load is reactive or EMF producing.

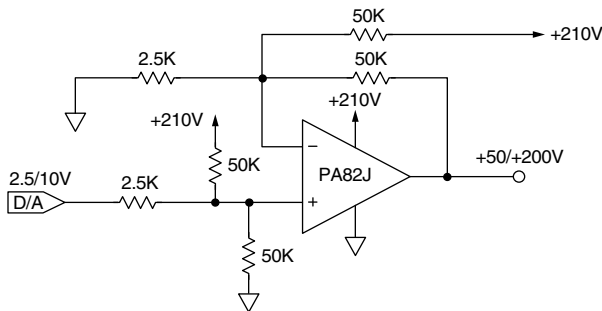

FIGURE 2A. TRUE SINGLE SUPPLY OPERATION

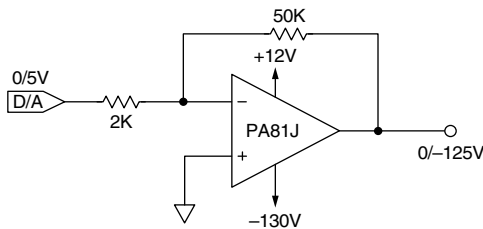

FIGURE 2B. ASYMMETRIC SUPPLIES

KNOW YOUR POWER DISSIPATION

Power requirements of the load are most often well known, but calculating the power dissipated inside the amplifier is not always simple.

For purely resistive loads, maximum internal power dissipation occurs when the output voltage equals half the supply voltage. This is the worst case to analyze if the amplifier does

not have to withstand short circuits. An example of DC application is the temperature controller in Figure 3.

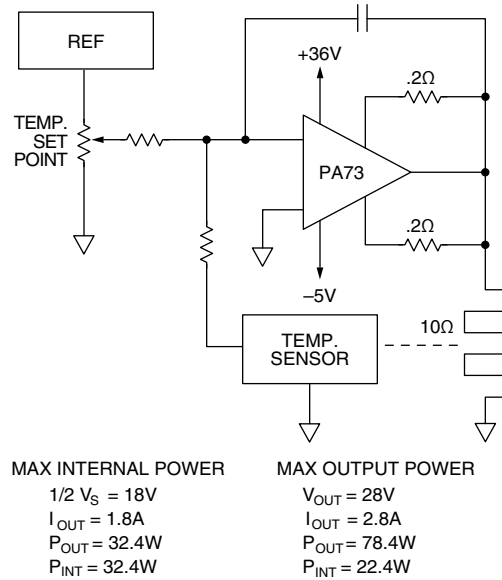

FIGURE 3. TEMPERATURE CONTROL CIRCUIT POWER LEVEL

Programmable power supplies (PPS) for automated test equipment must often tolerate short circuits in the device under test. For the PPS shown in Figure 4, the worst case dissipation will occur with a short to one of the 24V DUT supplies if the PPS is programmed to the opposite voltage. Assuming the current limit of the 24V supply is greater than the PPS limit, the PPS goes into current limit with considerably higher power levels than encountered under normal operation. Worst case for the amplifier could be its supply voltage plus the DUT supply voltage times the current limit.

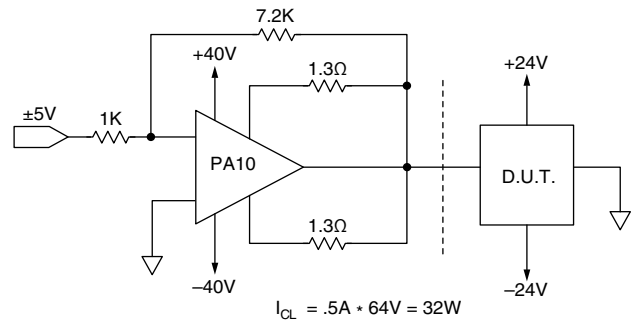

FIGURE 4. PPS POWER DISSIPATION CONSIDERATIONS

AC OUTPUTS ALLOW HIGH POWER LEVELS

If an AC drive has a frequency of 60Hz or greater, the half-wave period of the power dissipating waveform is shorter than the thermal time constant of the power amplifier. The resultant power averaging between the output transistors results in a lower thermal resistance. This lower thermal resistance immediately increases the power handling capability of a given amplifier.

Apex data sheets provide both AC and DC ratings of thermal resistance. Power levels specified on both the absolute maximum rating and the power derating typical performance graphs are based on DC thermal resistance. This means an AC only application is capable of delivering more power or running cooler (more reliably).

Sine wave circuits share a similarity with DC circuits. Maximum internal RMS power dissipation occurs when the peak

output voltage swings to 63.7% of supply voltage. Maximum internal power may be calculated as follows:

$$P = V_{SS}^2 / (2\pi^2 * R_L)$$

Where: V_{SS} = total rail-to-rail supply voltage
 R_L = load resistance

REACTIVE LOADS INCREASE DISSIPATION

When driving reactive loads, more caution is required due to the phase difference between V_o and I_o . The actual power dissipation may be several times higher than the equivalent resistive loads. In such cases, It is best to use a totally different, but equally simple, approach to calculate power dissipation (P):

$$P = P_1 - P_o$$

Where: P_1 = Power drawn from the power supply
 P_o = Real power delivered to the load

In calculating P1, use DC supply voltage and AVERAGE output current (RMS * .9003 [.9003 = AVG/RMS or $2/\pi \div \sqrt{0.5}$]). For example, a 1A RMS output, with supplies of $\pm 15V$, means $.9003 * 1 * 15 = 13.5W$ plus quiescent current * 30V.

Driving purely reactive loads means that all power drawn from the supplies is dissipated in the amplifier because the load power factor is reduced to zero.

DEALING WITH MOTOR DRIVES

Motor control applications often place brutal requirements on the driving circuit. Section A of Figure 5 shows two output transistors of a power amplifier and the motor with its ratings. It is important to recognize that the winding resistance and the voltage rating of the motor alone do not determine the running current. The back EMF of the motor must also be considered when calculating the running current. This EMF can be modeled as a battery whose voltage is proportional to instantaneous velocity as shown in Section B of Figure 5.

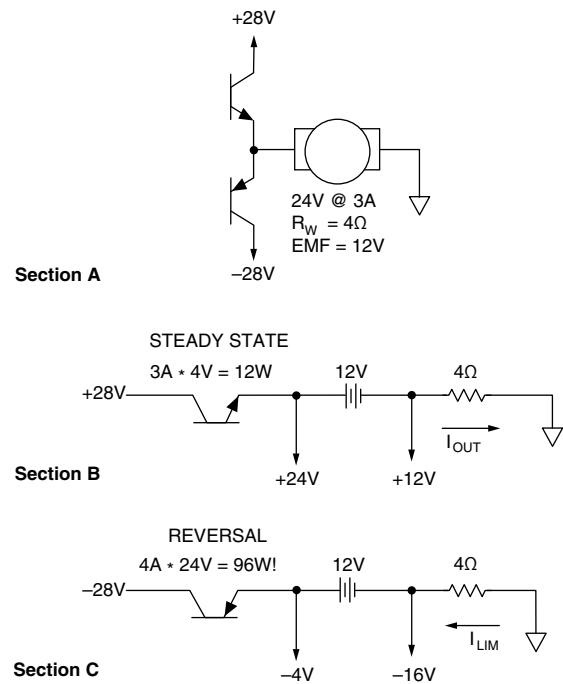

FIGURE 5. POWER DISSIPATION IN MOTOR DRIVES

When the amplifier is given a reversal command, it changes its output very quickly while the actual speed and EMF can diminish only as fast as mechanical system inertia is dissipated. The initial result of the vastly different response times between the electronics and the mechanics is shown in Section C of Figure 5. The amplifier has responded to its new drive command, but the EMF has not yet had time to change.

The model shows that if the amplifier could produce the programmed output level of -24V, a total of 36V would be applied across the winding resistance developing a current on 9A. In this situation, the output voltage is determined by the current limit of the amplifier rather than the control voltage. The programmed limit of 4A through the winding resistance produces 16V. Adding the initial 12V EMF places the amplifier output voltage at -4V. With 24V across the conducting transistor, the internal power dissipation is eight times the level encountered in steady state operation. Failure to analyze this situation has taken the lives of many power op amps.

A useful technique to maximize available power for steady state running requirements is to limit the rate of change of the drive voltage to approximately the same limitation imposed by the inertia of the mechanical system. In this manner, the extremely high power levels described can be avoided. In other words, fast reversal times can be traded off for high levels of running torque.

CIRCUIT DESIGNS TO INCREASE OUTPUT POWER

Two power op amps configured in a bridge circuit can double power levels. To illustrate the advantages of the bridge circuit, Figure 6 shows a composite where alternate connections transform the circuit from single ended to a bridge. A1 is a standard single ended power op amp which would drive the 4 ohm speaker. If A2 is added, it completes a bridge circuit. The resulting doubling of the voltage drive would be suitable for an 8 ohm speaker. With this trick, not only are power levels doubled, but the same supply is capable of powering either circuit. This is possible because the single ended circuit peak current demand utilizes only 50% of the supply capability. In contrast, the equal and opposite drive characteristics of the bridge circuit loads both positive and negative supply rails equally during each half cycle of the signal.

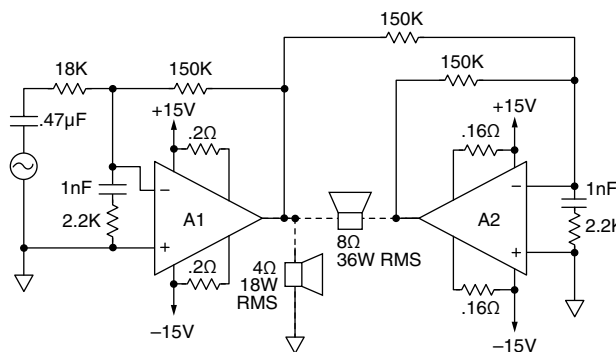

FIGURE 6. DOUBLING POWER WITH A BRIDGE

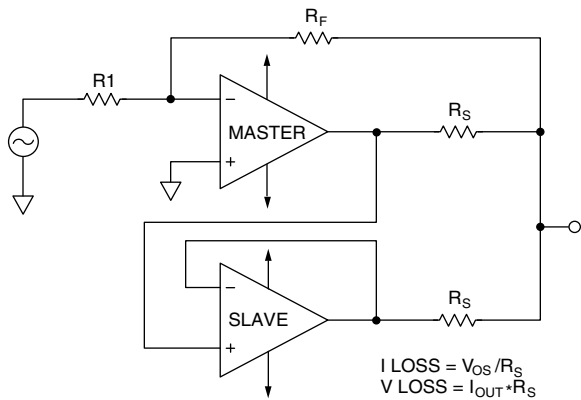

FIGURE 7. PARALLEL OPERATION

Parallel operation is often used to increase output current or wattage. However, due to their low output impedance, power op amps cannot be connected in parallel without modifying the circuits. Figure 7 illustrates one method of doing this. This uncommitted *master* amplifier, configured as required to satisfy the circuit function, has a small sense resistor inside its feedback loop. The *slave* amplifier is a unity gain buffer. Thus, the output voltages of the two amplifiers are equal. If the two sense resistors connected to the load are equal, the amplifiers share current equally. More slaves may be added as desired.

There are two factors to consider in the selection of the sense resistors. First, the output current will produce a voltage drop which adds to the supply requirements. Second, the voltage offset of the slave appears across the sum of the two sense resistors. Thus, a small current will circulate strictly between the two amplifiers. This wastes power. When this technique is used, it is recommended that inputs be limited in such a way that they demand only 50% of the typical slew rate of the amplifier. This prevents two amplifiers with different slew rates from generating large currents between each other during fast transitions.

PROPER HEATSINKS INCREASE OUTPUT POWER

With a given power op amp, the larger the heatsink is, the higher attainable output power can be. Furthermore, as power levels increase, it is more cost effective to use a larger heatsink.

To minimize space and weight, forced air cooling or even liquid cooling is often used with power amplifiers. While obviously easier to implement, forced air cooling gives a maximum improvement of only about 2:1. At higher power levels, liquid cooling becomes a more attractive option. Reasonable heatsink ratings, which can be achieved given an area 6 inches square and 2 inches tall, are 0.85°C per watt for free air cooling, 0.4°C per watt for forced air, and 0.05°C per watt for a liquid cooled system. See the Apex application note on heatsinking for more information.

THERMAL SHUTDOWN CAN HELP

Internal thermal protection can increase output power under nominal operating conditions because the amplifier shuts off when the substrate temperature exceeds safe limits. This allows the amplifier circuit design to be based solely on normal conditions but prevents excessive temperature during abnormally high power conditions.

The thermal shutdown feature is especially valuable in circuits such as programmable power supplies (PPS). Here the output voltage is the normal operating voltage of the unit under test. Occasionally the unit under test will be defective which may short the output of the PPS to ground; thus, power levels increase substantially. Thermal shutdown will simply shut the device off rather than lead to destruction. Thermal shutdown is not a panacea for all problems. It does not mean to disregard the second breakdown curves of the safe operating area. Assume the time constant for operation of the thermal shutdown is 250-500ms. This means the worst case power levels should not exceed the steady state second breakdown line of the SOA curve.

OPTIMIZING IS A TEAM EFFORT

Apex power op amps employ unique thermistor circuits that provide superior control of internal currents and offer exceptional specifications plus a superb quality record. With careful attention to design of the application, the end result will be advanced products of greater value.